

DETALIU FUNDATIE
STALPI AX A4, A1, C4, C1

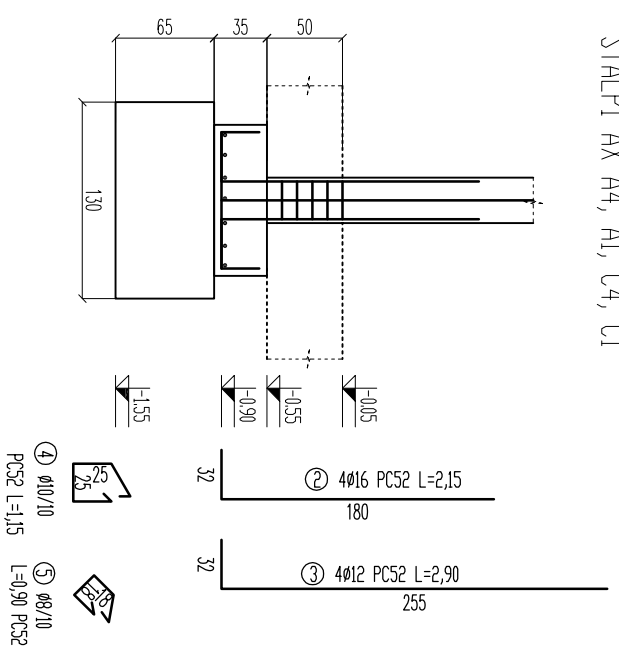

DETALIU FUNDATIE
STALPI AX A3, A2, B1, C3, C2

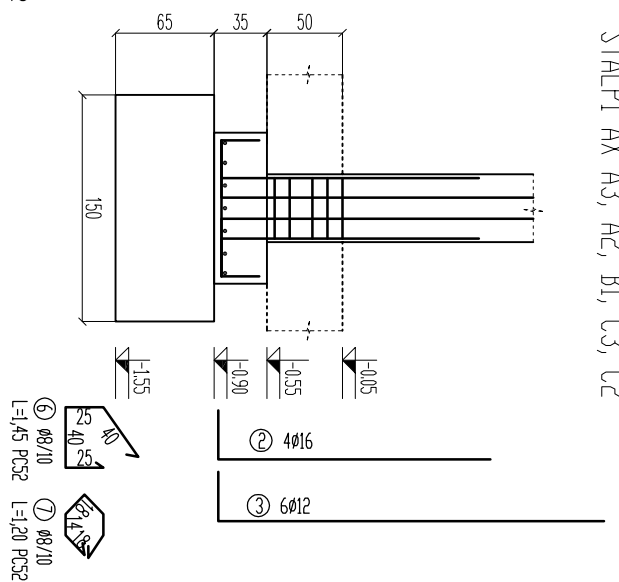

DETALIU FUNDATIE
STALPI AX B3, B2

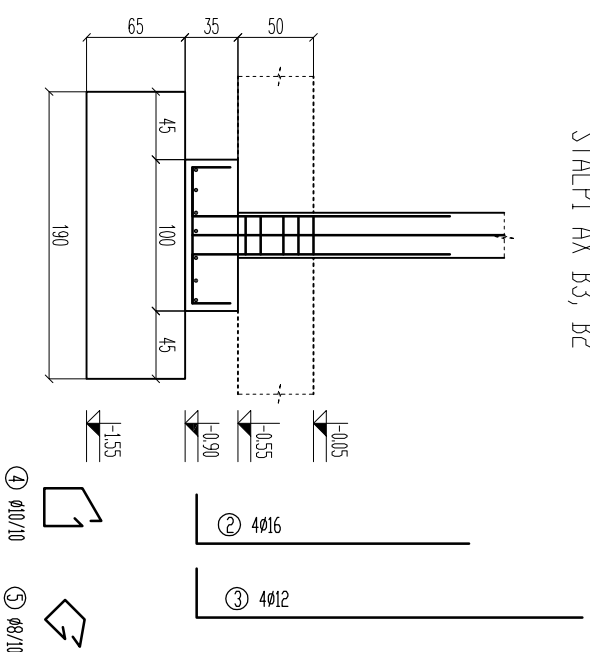

DETALIU FUNDATIE
STALPI AX B4

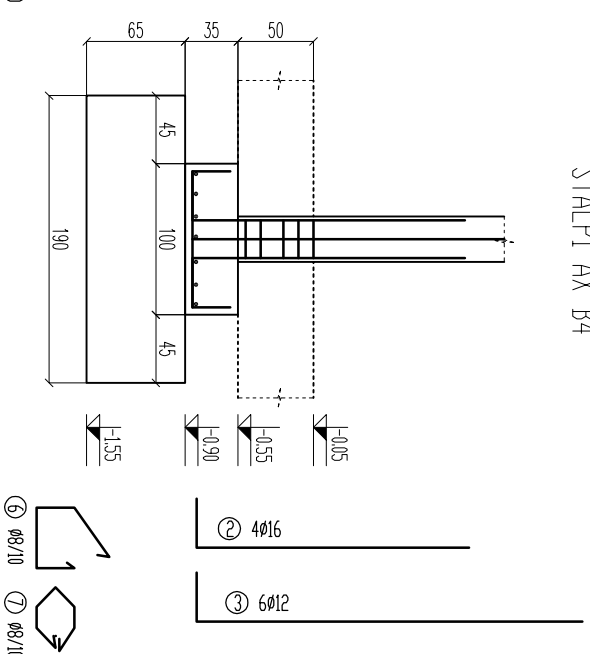

PLAN FUNDATIILII - DETALII

1/50

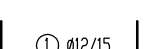
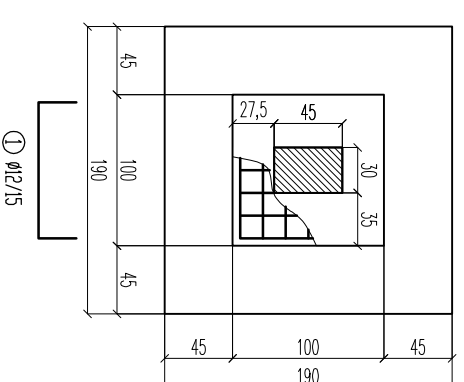
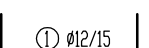
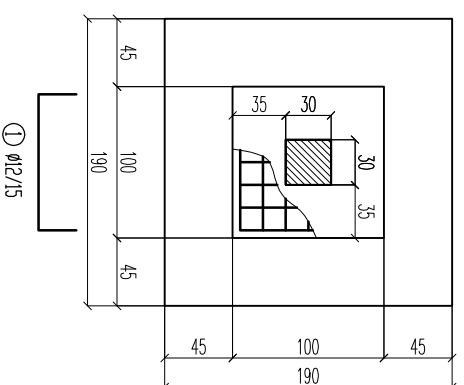
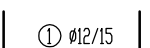
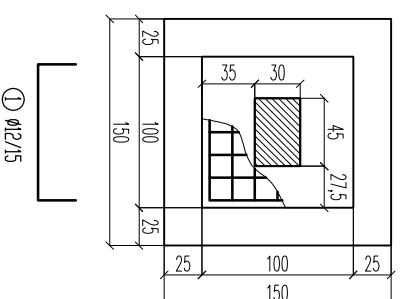
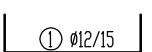
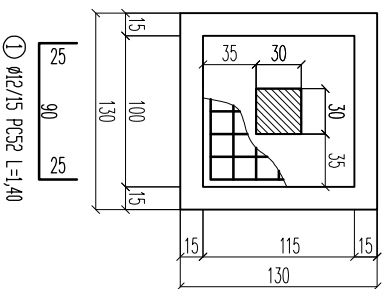

DETALII ARMARE FUNDATIE
STALPI INTRARE

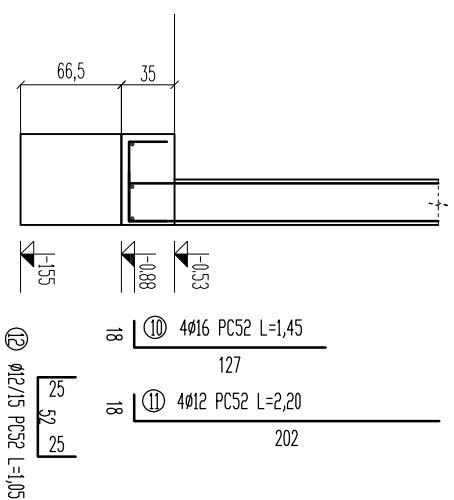
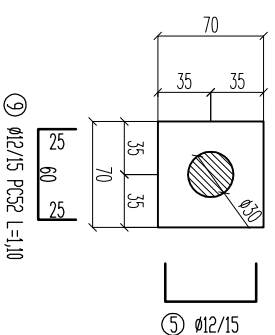
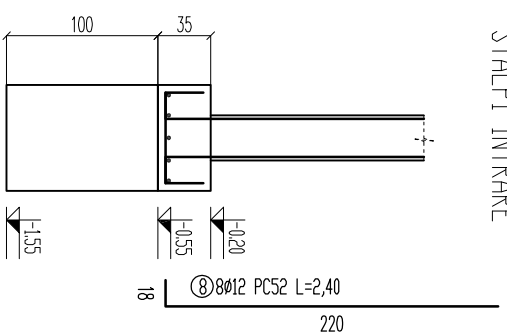

DETALII ARMARE FUNDATIE
STALPI AX A1', B1', C1'

CLASIFICARE CF.P100/06: CLASA III DE IMPORTANTA,
AMPLASAMENT: OTOPENI, jud. ILFOV
Tc=1,5 sec, qg=0.24
COTA ±0.00 ESTE COTA PARDOSELI FINITE LA PARTER

BETON
BETON SIMPLU C8/10
BETON ARMAT C20/25
OTEL P.c. 52, 06 37